

1. Appearance



2. X-extension unit retrofitting kit

Part No.	Name	Remarks
911604100T00	X-EXTENSION UNIT SET NEW FRAME WITH TABLE :BP/BR :*1200S[T]	With center table
911604200T00	X-TEXTENSION UNIT SET NEW FRAME WITHOUT TABLE :BP/BR :*1200S[T]	Without center table

Details

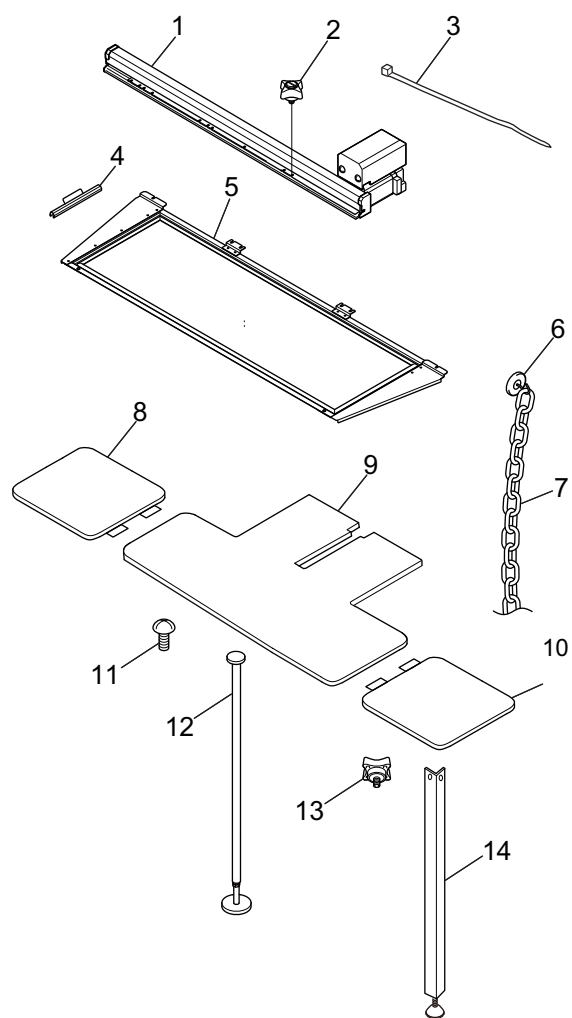

No.	Name	Q'ty	Remarks
1	Z-SPEC. FRAME :0001/1200S[A]	1	
2	KNOBBED SCREW :NO.2 :M5*6[S]	6	
3	BUNDLING BAND	2	
4	BORDER FRAME CLIP :L180	4	
4	BORDER FRAME CLIP :L300	8	
5	BORDER FRAME :0001/036*1200S	1	
6	MAGNET HANGER :CR-MG101	4	
7	PC CHAIN	2	
8	SIDE TABLE L	1	Set parts
9	CENTER TABLE (Refer to the figure A.)	1	Set parts
10	SIDE TABLE R	1	Set parts
11	TRUSS HEAD SCREW :M4*6	12	
12	TABLE SUPPORT[A]	1	
13	KNOBBED SCREW :NO.2 :M5*6[S]	4	
14	TABLE SUPPORT :X-EXTENSION UNIT	2	

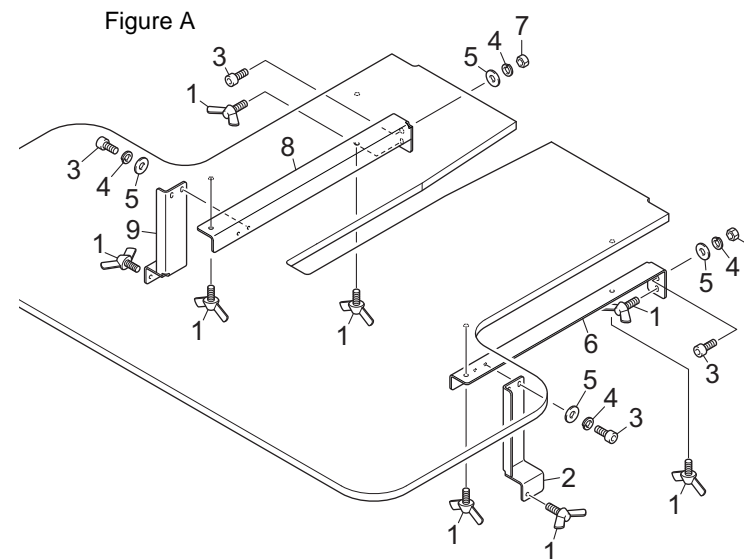

Number	Name	Quantity
1	WING BOLT :TYPE 2 :M5*10	8
2	SUPPORT :TABLE :R	1
3	HEXAGON SOCKET HEAD CAP SCREW :M5*10	6
4	SPRING WASHER :M5	6
5	PLAIN WASHER :M5*10*T0.8	6
6	BASE :TABLE SUPPORT :R	1
7	HEXAGON NUT TYPE 1 :M5	2
8	BASE :TABLE SUPPORT :L	1
9	SUPPORT :TABLE :L	1

3. How to attach

(1) Detach the motor cover.



(2) Detach three types of connectors and the bundling band. (3) Remove hexagon socket head cap screws which fix X-axis drive system.



(4) Detach the X-axis drive system.



(5) Join the side table to the center table by using truss head screws (M4*6). (6) Attach the center table to the machine. About installation method, refer to [How to install center table] at the back page.

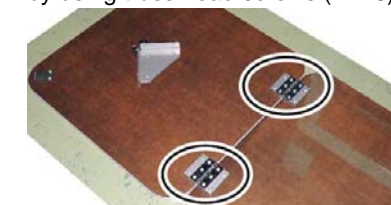

For the case without the center table, attach the hinge bracket to your machine table by using eight pieces of tapping screws (M5*16 L).

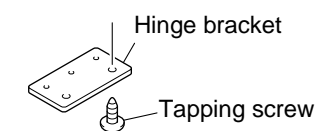

(7) Attach X-extension unit, and fix it by using hexagon socket head cap screws.



(8) Connect three types of connectors, and fix them by using the bundling band and attach the motor cover.

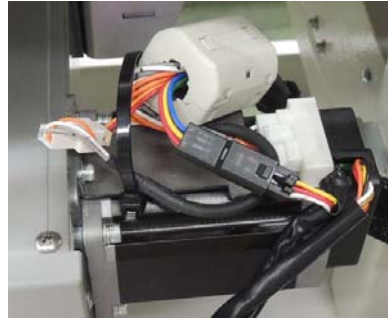

(9) Attach the border frame by using knobbed screws.

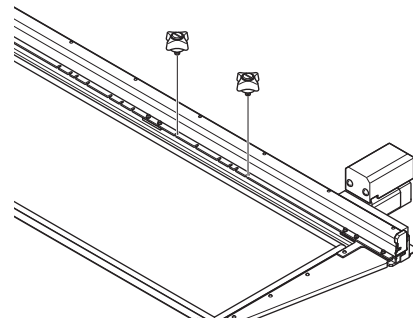

(10) Set the center table support and the side table support under the table.

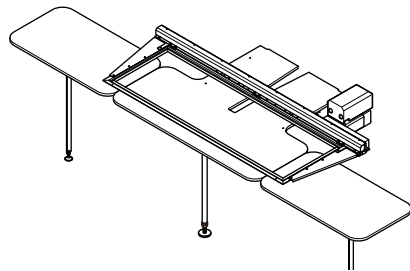

(11) Fix the side table support by using knobbed screws.



(12) Adjust the height of the center table support and the side table support.

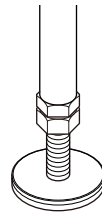

(13) Attach the magnet hanger to the bracket under the side table.



(14) Attach the magnet hanger to the main body of the machine, and hang the chain on it.

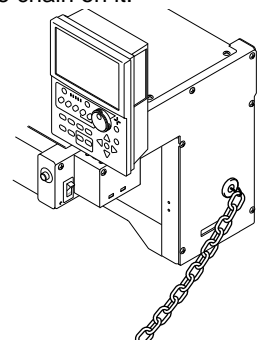

4. Setting on the operation panel

Select "X-EXT" in the frame type setting (C-7 Frame Type).

To use X-extension unit, the software of 1.05 or later version is necessary.

[How to install center table]

(1) Attach the table support 1 to the stand 3 by using the wing bolt 2.

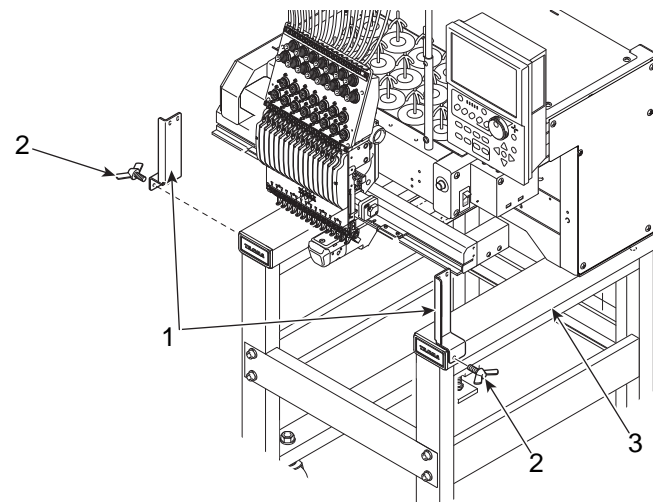

(2) Detach the box cover 4, and attach the screw 5 (hexagon socket head cap screw M5*10) to the stand 3. Head part (tip) of the screw 5 is for positioning the table support base 6. At this time, attach the screw 5 to any position.

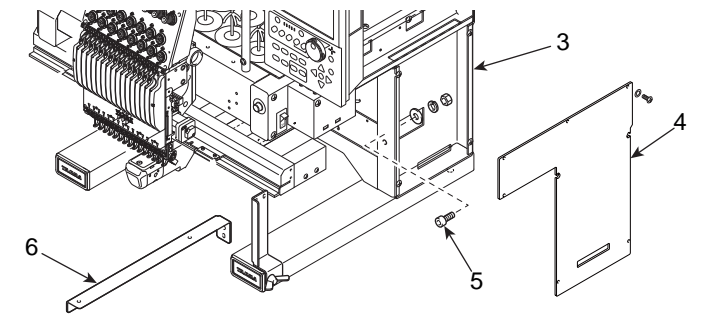

(3) Attach the table support base 6 to the table support 1 by using screws 7 (hexagon socket head cap screw M5*10).

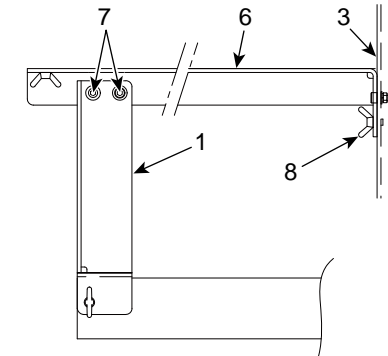

(4) Attach the table support base 6 to the stand 3 by using the wing bolt 8.

(5) Mount the table 9 on the table support base 6, and fix the table by using wing bolts 10.

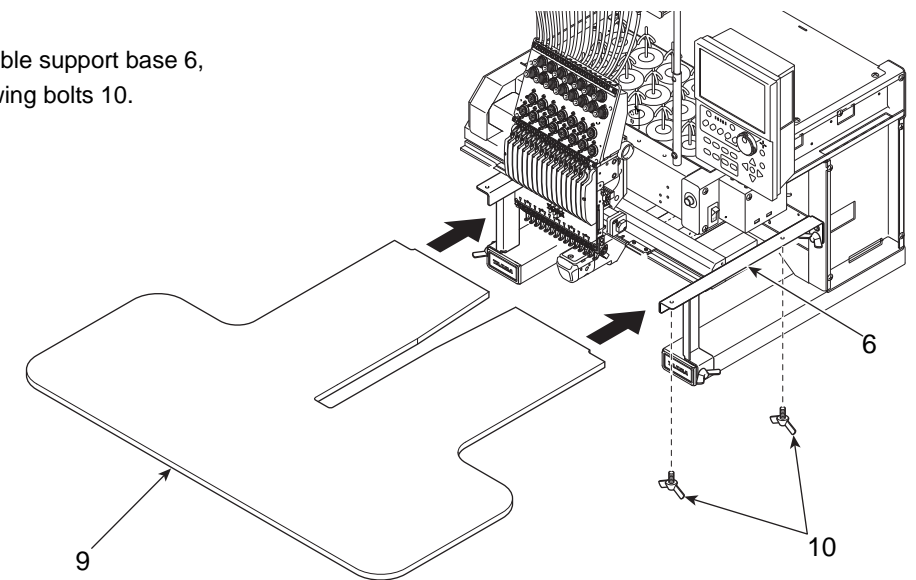

(6) Check if the top of the table 9 almost aligns with the top 11 of the needle plate. When there is difference of 0.5 mm or more, loosen the screw 5, the screw 7 and wing bolts 8 to adjust the height of the table 9.

